



TA70  
INSTALLATION  
GUIDE  
01794-00 AB

## TRIG WARRANTY

Trig Avionics warranty runs for a two-year period, starting from the date of installation.

This warranty covers repair and/or replacement at our option, of any parts found to be defective, provided such defects in our opinion are due to faulty material or workmanship and are not caused by tampering, abuse, or normal wear.

Our warranty service is provided FCA our location or our other associated Trig Service Centres.

Trig Avionics will not accept or pay for any charges for warranty work performed outside our factory without prior written consent.

This warranty applies only to products in normal use. It does not apply to units or circuit boards defective due to improper installation, physical damage, tampering, lightning or other electrical discharge, units with altered serial numbers, or units repaired by unauthorized persons or in violation of Trig Avionics service procedures.

Trig Avionics assumes no responsibility for any consequential losses of any nature with respect to any products or services sold, rendered, or delivered.

### **Out of Warranty Repairs**

Trig provides product support beyond the warranty period of two years. After this period, any avionics requiring repairs should be returned to one of our Approved Trig Dealers. If a repair is necessary this will be charged at a standard rate, irrespective of the nature of the fault. Trig guarantees to repair or replace a product even if the cost of the repair exceeds our standard charge. If you wish to access our out of warranty support, then please contact your Approved Trig Dealer or Trig Support for further information.

Hardwareweg 3  
3821 BL Amersfoort  
Netherlands

+31 33 782 0900

Thank you for purchasing a Trig TA70 GPS antenna.

This pack contains installation information, installation kit, and support and warranty information.

All our avionics are thoroughly tested prior to despatch and are designed to provide years of trouble free service. To access technical support for your Trig Avionics product you should first contact your Approved Trig Dealer.

If you have any further technical questions, then please access your closest Trig Service Centre through the support section of our website.

[www.trig-avionics.com/support/](http://www.trig-avionics.com/support/)

Thanks,

The Trig Team  
[enquiries@trig-avionics.com](mailto:enquiries@trig-avionics.com)

## INSTALLATION GUIDE

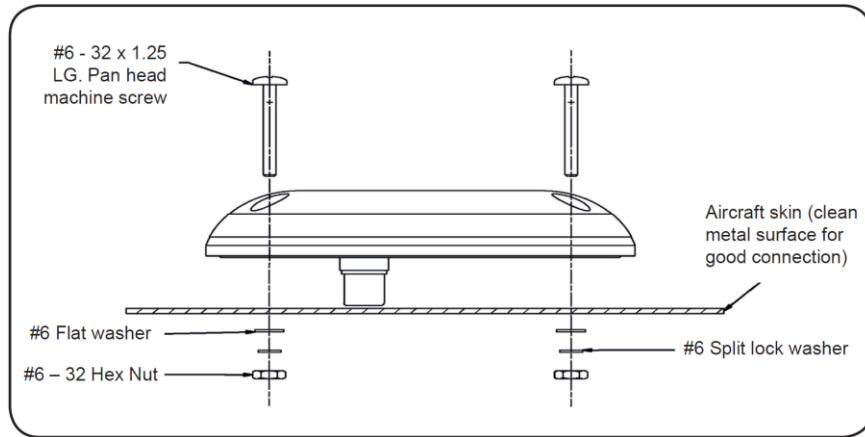

1. **Mounting location:** The TA70 antenna must be mounted in a location that will assure the best possible (360° at the horizon) unobstructed view of the GPS satellite constellation in level flight (on the top of the aircraft away from projections such as tail surfaces or large antennas). Mounting orientation is not critical and no additional ground plane is required if mounted on a composite airframe.
2. You should also try to locate the antenna in an area that will keep the coaxial cable transmission line as short as possible. This will assure maximum signal strength to the GPS receiver.
3. Using the mounting template provided, drill the four required screw holes and the single antenna connector hole.
4. Mount the antenna using the hardware provided (as shown in the diagram) and torque all screws to a maximum of 10 in. lb. or 1.1 Nm.
5. Apply a sealant (RTV is recommended) over the screw heads and around the periphery of the antenna.

## SPECIFICATION SHEET

### TA70 – External Aircraft Antenna for GPS Receivers

The TA70 is a permanently mounted external aircraft antenna, designed for use with handheld and panel mount GPS receivers which provide +5 volts DC on their antenna connector.

It is an active (amplified) antenna providing an average of 28.5 dB gain over a passive (non-amplified) antenna.

The antenna is FAA certified to TSO-C190.

#### Specifications:

Frequency:	1575.42 MHz $\pm$ 3 MHz
Antenna Gain:	0.75 dBic typical @ zenith
Impedance:	50 ohm nominal
VSWR:	1.2:1 typical, 1.5:1 max.
Filtering:	-25.5 dB typical @ $\pm$ 50 MHz
Noise Figure:	2.5 dB maximum
Gain:	26.5 to 30.5 dB
DC Power Requirement:	4.5 to 14.4 VDC 40 mA typical
Temperature:	-55° C to +70° C
Connector	TNC Female (plug not included)